



Sheer
Driving Pleasure



THE 2

COUPÉ
CONVERTIBLE

THE BMW 2 SERIES COUPÉ.
THE BMW 2 SERIES CONVERTIBLE.



DIGITAL DISCOVERY:
THE NEW BMW BROCHURES APP.



More information, more sheer driving pleasure: The new BMW brochures app offers a digital and interactive BMW experience like never before. Download the BMW brochures app for your smartphone or tablet now and rediscover your BMW.

INNOVATION AND TECHNOLOGY.



18 BMW EfficientDynamics



20 BMW Personal CoPilot
21 BMW ConnectedDrive



22 Suspension and safety

EQUIPMENT.



24 Models and lines



32 Additional equipment



36 Exterior colours

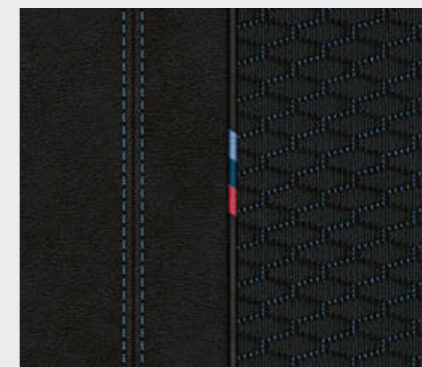

38 Interior colours



40 Wheels and tyres



41 Original BMW Accessories

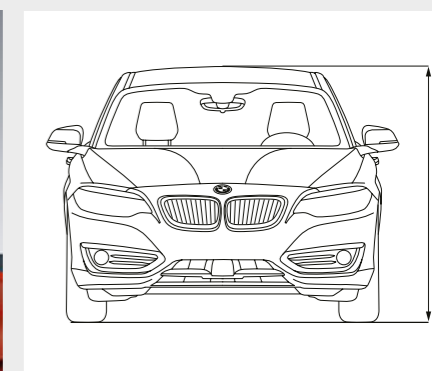

42 Technical data



RE-WRITING
THE RULE BOOK.



EXCEPTIONAL PERFORMANCE.

VARIABLE SPORT STEERING* FOR NOTICEABLY MORE DIRECT RESPONSE || 50:50 WEIGHT DISTRIBUTION FOR MAXIMUM AGILITY || BEST-IN-CLASS DYNAMICS IN THE COMPACT SEGMENT

* Available as optional equipment.



HIGH-SPEED PURSUIT. WITH YOUR EYES.

ICONIC DESIGN || ELONGATED BONNET || SWEEP-BACK GREENHOUSE ||
LONG WHEELBASE || SLEEK SILHOUETTE || ELEGANT SWAGE LINES



EYE-CATCHING AND COMPELLING.

HEADLIGHTS WITH FOCUSED HEXAGONAL DESIGN* || LARGER, MORE DYNAMIC AIR INLETS || EXPRESSIVE FRONT DESIGN

* Available as optional equipment.



THE HEART LEADS. THE MIND FOLLOWS.

ERGONOMIC CONTROLS WITH CONSISTENT DRIVER ORIENTATION || PREMIUM INTERIOR WITH TOP-CLASS WORKMANSHIP || BMW CONNECTED DRIVE WITH WIRELESS APPLE CAR PLAY® PREPARATION*

* Available as optional equipment.



OPEN AND UNALLOYED.

EXPRESSIVE REAR DESIGN II LOW VISUAL CENTRE OF GRAVITY II
LIGHTS WITH EDGIER DESIGN II FULLY RETRACTABLE ROOF FOR
MAXIMUM CONVERTIBLE FEELING



GROUNDBREAKING.

ONE THING IS CERTAIN: THESE TWO ARE DIFFERENT. THEY CREATE FASCINATING EXPERIENCES ON EACH DRIVE, RANGING FROM THE EXPLICITLY SPORTY TO THE EXCITINGLY SENSUAL. WITH A COMPACT DESIGN EVOKING A SENSE OF UNLIMITED FREEDOM AND PALPABLE ATHLETICISM THAT COMMUNICATES ITSELF BEFORE THE CAR HAS EVEN MOVED AN INCH. WITH AN INTERIOR THAT BOASTS PREMIUM MATERIALS AS WELL AS SUPREME WORKMANSHIP, ALONG WITH INNOVATIVE TECHNOLOGY EFFORTLESSLY CONNECTING ITS OCCUPANTS WITH THE OUTSIDE WORLD. DISCOVER PASSION. DISCOVER CHARISMA. **DISCOVER THE BMW 2 SERIES COUPÉ AND CONVERTIBLE.**

www.bmw.com/efficientdynamics

MORE POWER FROM LESS FUEL.

More power from three to 12 cylinders. Consume less, experience more – the **BMW TwinPower Turbo engines** offer the greatest possible dynamic performance with the greatest possible efficiency thanks to the newest injection systems, variable output control and sophisticated turbocharger technology. Whether diesel or petrol, and no matter how many cylinders, the engines from the BMW EfficientDynamics engine family allow markedly more agile power delivery and outstanding responsiveness even at low rpm, while being fuel-efficient and low in emissions.

MORE DRIVING PLEASURE, LESS EMISSIONS.

BMW EfficientDynamics is a technology package that includes not only the drive, but rather the whole vehicle concept and intelligent energy management. Provided as standard in every BMW, a variety of innovative technologies contribute to continuously improving efficiency. Via engine efficiency measures, electrification, lightweight construction methods and optimised aerodynamics, BMW has managed to reduce the CO₂ emissions of its fleet significantly.

MORE DYNAMICS, LESS WEIGHT.

Lower weight with intelligent lightweight construction. Special consideration for every last detail – intelligent lightweight construction means that the optimal material is found and implemented for each part of the vehicle. With extremely light high-tech materials such as aluminium and carbon fibre, **BMW EfficientLightweight** is pursuing the goal of minimising vehicle weight. That leads to even more dynamic performance, increased stability and heightened safety and comfort.



DRIVING EXPERIENCE CONTROL INCL. ECO PRO.

Driving Experience Control offers the driver the choice between the standard COMFORT mode, the more efficient ECO PRO mode, and the SPORT and SPORT+² * modes, for an even more dynamic drive. ECO PRO mode adjusts the characteristics of the Steptronic transmission (if present) and the heating/air conditioning settings to make the drive as fuel-efficient as possible.

STEPTRONIC TRANSMISSION.

The 8-speed Steptronic transmission² * ensures particularly smooth gearshifts and outstanding driving comfort, thanks to fast engine speed transitions and tightly spaced gear ratios. It unites superb comfort with impressive dynamics and increased fuel efficiency.

AUTOMATIC START/STOP FUNCTION.

The Automatic Start/Stop function switches off the engine when the vehicle comes to a temporary standstill (e.g. at traffic lights or in a traffic jam), which can reduce overall fuel consumption. When the driver presses down on the clutch (manual transmission) or takes their foot off the brake (Steptronic transmission), the engine automatically starts up again in a fraction of a second.

IN THE BMW 2 SERIES COUPÉ AND BMW 2 SERIES CONVERTIBLE.



BMW 218i Coupé // Convertible

- BMW TwinPower Turbo 3-cylinder petrol engine with 100 kW (136 hp) and 220 Nm torque
- Acceleration 0–100 km/h: 8.8 [8.9] s // 9.4 [9.6] s
- Top speed: 210 [210] km/h // 207 [205] km/h
- Combined fuel consumption: 6.0–6.2 [5.7–5.9] l/100 km // 6.3–6.5 [6.1–6.3] l/100 km
- Combined CO₂ emissions: 137–140 [130–133] g/km // 144–148 [139–143] g/km

BMW 220i Coupé // Convertible

- BMW TwinPower Turbo 4-cylinder petrol engine with 135 kW (184 hp) and 270 Nm torque
- Acceleration 0–100 km/h: [7.2] s // [7.7] s
- Top speed: [230] km/h // [226] km/h
- Combined fuel consumption: [5.8–5.9] l/100 km // [6.1–6.2] l/100 km
- Combined CO₂ emissions: [132–135] g/km // [139–142] g/km

BMW 230i Coupé // Convertible

- BMW TwinPower Turbo 4-cylinder petrol engine with 185 kW (252 hp) and 350 Nm torque
- Acceleration 0–100 km/h: [5.6] s // [5.9] s
- Top speed: [250]¹ km/h // [250]¹ km/h
- Combined fuel consumption: [5.8–6.0] l/100 km // [6.2–6.3] l/100 km
- Combined CO₂ emissions: [132–138] g/km // [141–144] g/km

BMW M240i Coupé // Convertible / M240i xDrive Coupé // Convertible

- M TwinPower Turbo inline 6-cylinder petrol engine with 250 kW (340 hp) and 500 Nm torque
- Acceleration 0–100 km/h: [4.6] s // [4.7] s
- Acceleration 0–100 km/h xDrive: [4.4] s // [4.6] s
- Top speed: [250]¹ km/h // [250]¹ km/h
- Top speed xDrive: [250]¹ km/h // [250]¹ km/h
- Combined fuel consumption: [7.3–7.4] l/100 km // [7.6] l/100 km
- Combined fuel consumption xDrive: [7.8–8.0] l/100 km // [8.3–8.4] l/100 km
- Combined CO₂ emissions: [167–168] g/km // [172–173] g/km
- Combined CO₂ emissions xDrive: [178–181] g/km // [188–191] g/km

BMW 218d Coupé // Convertible

- BMW TwinPower Turbo 4-cylinder diesel engine with 100–110 kW (136–150 hp) // 110 kW (150 hp) and 320 Nm torque
- Acceleration 0–100 km/h: 8.5–9.2 [8.3–8.9] s // 9.0 [8.8] s
- Top speed: 211–213 [211–213] km/h // 208 [205] km/h
- Combined fuel consumption: 4.7 [4.4–4.5] l/100 km // 5.0–5.1 [4.7–4.8] l/100 km
- Combined CO₂ emissions: 122–124 [116–119] g/km // 131–134 [123–127] g/km

BMW 220d Coupé // Convertible

- BMW TwinPower Turbo 4-cylinder diesel engine with 140 kW (190 hp) and 400 Nm torque
- Acceleration 0–100 km/h: 7.2 [7.1] s // 7.6 [7.5] s
- Top speed: 230 [230] km/h // 225 [225] km/h
- Combined fuel consumption: 4.7–4.8 [4.5–4.6] l/100 km // 5.1–5.2 [4.7–4.8] l/100 km
- Combined CO₂ emissions: 124–127 [120–121] g/km // 133–136 [124–126] g/km

BMW 220d xDrive Coupé

- BMW TwinPower Turbo 4-cylinder diesel engine with 140 kW (190 hp) and 400 Nm torque
- Acceleration 0–100 km/h: [7.0] s
- Top speed: [225] km/h
- Combined fuel consumption: [5.0–5.1] l/100 km
- Combined CO₂ emissions: [132–135] g/km

¹ Electronically limited.
² Available as optional equipment.

* The availability of some equipment features and functions depends on engine variants or additional options. The market and production availability may vary. You can find detailed information about terms, standard and optional equipment at www.bmw.com or from your BMW Partner.

Further information on fuel consumption and CO₂ emissions can be found in technical data and the price list.
Figures in [] are for vehicles with Steptronic transmission.

BMW Personal CoPilot

By your side, when you decide.

THE INNOVATIVE BMW ASSISTANCE SYSTEMS.

Enjoy the ultimate in comfort and safety with the BMW Personal CoPilot. Whether it's for driving or parking, you can rely on BMW Personal CoPilot driver assistance systems in every situation. The most cutting-edge systems, such as radar, ultrasound and cameras, dependably register the vehicle's surroundings, forming the basis for intelligent driver assistance systems. Either activated when desired, or as emergency assistance in the background – BMW Personal CoPilot assistance systems make every journey in your BMW even safer and more enjoyable.

CLOSER TO AUTONOMOUS DRIVING THAN EVER BEFORE.

Autonomous driving is not a utopia, it is the future: All over the world, BMW Personal CoPilot test vehicles are already driving completely independently without the driver's intervention and not only show impressively how mobility will change in the near future – they also offer an outlook on the next level of driving pleasure. Even today, BMW Personal CoPilot assistants already offer a large number of intelligent semi-automated systems that actively support and relieve the driver in almost every driving situation.

SIMPLY PARK IT.

Intelligent parking assistance systems from BMW Personal CoPilot are available so that you don't just look forward to every ride in your BMW, but also to parking. For example, the Parking assistant already displays suitable parking spaces as you drive past and, depending on the BMW model, runs the parking process either partially or completely independently. But here too, automation will continue to advance, so that in the future it will be possible for vehicles without drivers to search for a parking space and execute the parking process autonomously.

ACTIVE CRUISE CONTROL WITH STOP&GO FUNCTION.

Active cruise control with Stop&Go function^{4,*} incl. Approach control warning with braking function maintains a speed preselected by the driver, as well as the distance to the vehicle ahead. The vehicle takes over accelerating and braking and keeps the predetermined distance to the car ahead even in slow-moving traffic and down to a stand-still in traffic jams.

PARKING ASSISTANT.

The Parking Assistant^{4,5,*} makes parking parallel and perpendicular to the road easier. The system works by measuring even tight potential parallel parking spaces while driving past at a low speed. When a suitable space has been found, the Parking Assistant takes over the steering, while the driver is responsible for selecting the correct gear, as well as pressing the accelerator and brakes.

DRIVING ASSISTANT.

Driving Assistant^{3,4,*} combines the Lane Departure Warning and Approach control warning systems. When travelling at speeds between 10 and 60 km/h, the Approach control and person warning with light city braking function issues a warning if there is a risk of collision with vehicles or pedestrians, and brakes the vehicle in the event of an emergency. At speeds above approx. 70 km/h, the Lane Departure Warning draws the driver's attention to an unintentional lane change by means of slight vibrations of the steering wheel.

IN THE BMW 2 SERIES COUPÉ AND BMW 2 SERIES CONVERTIBLE.

The key visual for BMW Personal CoPilot shown here is an exemplary, artistic representation, which can deviate from the design and equipment of the BMW model described in this medium.

¹ ConnectedDrive Services and the Navigation system Professional are required for use. Use of a flat-rate music service from a BMW music partner depends on the terms and conditions of the respective music partner.

² Apple CarPlay[®] compatibility and supported functions depend on the model year and the software installed on the iPhone[®]. When the Apple CarPlay[®] preparation is in use, selected vehicle data is transferred to the phone. The mobile phone manufacturer is responsible for any further processing of the data.

BMW ConnectedDrive

Connected to be free.

Innovation and technology 20 | 21

CONNECTED FOR OVER 20 YEARS.

Focused on the future – from the very beginning. By the 1990s, BMW had already made headway in connected mobility. Another milestone of the digital future was surpassed in 2004: vehicles with built-in SIM cards. Then came the first online functionality, Google Services and innovative display systems such as the BMW Head-Up Display. Throughout this process, the desires of the customer have always taken centre stage. In a first for a premium automobile manufacturer, BMW makes it possible to book and pay for services flexibly via the BMW ConnectedDrive Store, in the vehicle or on a computer at home. And with the introduction of BMW Connected, the Open Mobility Cloud and the BMW Intelligent Personal Assistant, BMW is taking the next steps into the future of mobility.

MORE THAN 20 SERVICES IN THE BMW CONNECTED DRIVE STORE.

ConnectedDrive open the gate to the digital world of BMW. Use vehicle apps such as news, weather, office or online search on the go and be well informed at all times. Via the ConnectedDrive Store or directly in your BMW, you can book additional digital services such as Connected Music or Concierge Service – anytime, anywhere, easily and flexibly.

IN TOUCH 24/7, WITH BMW CONNECTED.

Are the doors of my car really locked, when should I leave my office to arrive in time for dinner at the fancy Italian restaurant and how will I find my way there? As your personal mobility assistant, the BMW Connected App can easily help you with all these questions. It connects you directly with your car, giving you access before and during your trip to numerous functions, which make every drive simpler and more comfortable.

ONLINE ENTERTAINMENT.

Listen to your favourite music wherever you are. Classical on the motorway, jazz during rush hour and pop when you're cruising. With Online Entertainment^{1,4,*}, you can directly stream as many as 30 million songs without any limits courtesy of BMW's music partners, Deezer and Napster, using the SIM card installed in your vehicle.

CONCIERGE SERVICE.

Will it be sunny tomorrow in Rome? When does my flight take off? The Concierge Service^{4,*} is there to help when you are travelling and can support you with any request at the touch of a button. Whether that is a booking at a restaurant, a hotel or a cinema. You can even use it for payments. Wherever you are, whatever you need, the Concierge Service is by your side.

PREPARATION FOR APPLE CAR PLAY[®].

Why go without the features of your iPhone in your BMW when you can continue operating it as usual? The preparation for Apple CarPlay^{®2,4,*} gives you remote access to telephony as well as apps like iMessage, WhatsApp, TuneIn, Spotify and Apple Music. You can also use the voice button on the steering wheel to access Siri, Apple's voice assistant.

IN THE BMW 2 SERIES COUPÉ AND BMW 2 SERIES CONVERTIBLE.

³ Function may be limited in darkness, fog or bright glare.

⁴ Available as optional equipment.

⁵ The driver is responsible for constantly monitoring the automated parking procedure in accordance with local road laws.

*The availability of some equipment features and functions depends on engine variants or additional options. The market and production availability may vary. You can find detailed information about terms, standard and optional equipment at www.bmw.com or from your BMW Partner.

■ Standard equipment □ Optional equipment



The **rear-wheel drive** forms the basis for classic BMW steering precision, agility and sporty driving characteristics. Seeing as propulsion comes from the rear instead of the front wheels, it enables highly sensitive steering and the ideal weight distribution of 50:50. This ensures great traction and directional stability on bends.

The intelligent **BMW xDrive all-wheel drive system** smoothly and variably distributes drive power to the front and rear wheels for maximum traction, driving dynamics and safety in every driving situation. For even better agility, the electronically controlled power distribution counterbalances over and under-steering on bends, among other things.

An ideal **axle load distribution of 50:50** helps ensure great directional stability, agile handling and a precise steering response. While at the same time, a lower centre of gravity and shorter overhangs further improve driving characteristics.

The **Dynamic Stability Control (DSC)** with extended functionality stabilises the vehicle as soon as any skidding motion is detected. Its extended functionality includes Cornering Brake Control (CBC), the hill-start and braking assistant, brake drying and braking readiness. For even more athletic driving, the Dynamic Traction Control (DTC) function allows increased wheel slip.

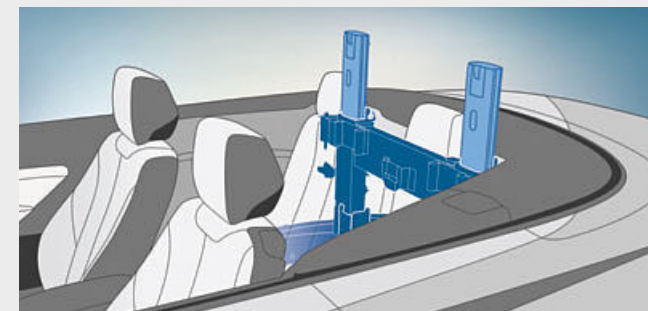

■ The **Roll-over protection system¹** in the rear headrests combined with the roll-over bar integrated into the windscreen frame forms the "passenger compartment". In case of accident the protective bars integrated into the headrests extend in fractions of a second to significantly improve head protection should the car roll over – guaranteeing a higher degree of safety.

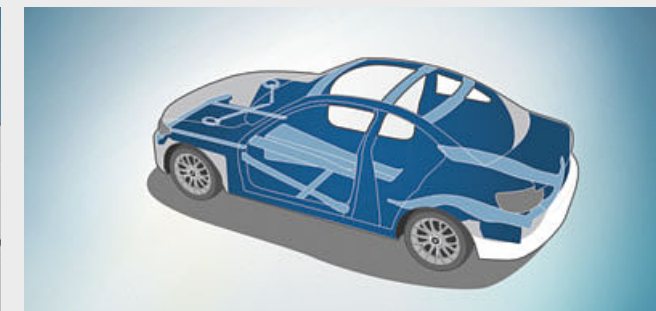

■ The functional structure of the **Passenger cell** is composed of a specialised system of beams and nodal connections, featuring strategically deployed high-strength materials so as to deliver maximum passive safety in the event of front, side and rear collisions.

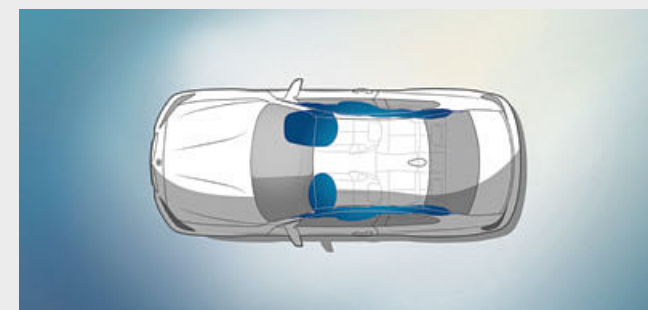

■ **Airbags** for driver and front passenger are part of the optimally coordinated safety components in a BMW. Overall, six airbags provide targeted protection: the driver and front passenger airbags, the head airbags for the entire window surface on the side², and the side airbags integrated into the front seat backrests.



■ The **Tyre pressure indicator** shows the exact air pressure at all times and automatically warns the driver of any loss of pressure. The system uses sensors to record data for each tyre before transmitting it wirelessly to a control unit. So the Tyre pressure indicator is capable of displaying both slow and rapid loss of air pressure.



□ If there is an accident, time is of the essence. **Intelligent Emergency Call*** gets help and can even save lives in case of an emergency. It contacts specially trained call centre agents in native language who offer support to you and your passengers until the emergency services arrive. The first responders also receive important information directly.



□ The **Adaptive LED headlights** include low-beam and high-beam headlights and turn indicators with full LED technology. The equipment also features BMW Selective Beam, cornering lights, daytime running lights and Adaptive headlights with variable light control for excellent illumination of the road ahead and better visibility in the dark.

¹ Only available for the BMW 2 Series Convertible.
² Side head airbags only available in the BMW 2 Series Coupé.

*The availability of some equipment features and functions depends on engine variants or additional options. The market and production availability may vary. You can find detailed information about terms, standard and optional equipment at www.bmw.com or from your BMW Partner.

BASE.

Discover even more with the new BMW Brochures app. Available now, for your smartphone and tablet.



■ All the controls in the driver-oriented cockpit follow an intuitive layout. An automatic air conditioning system with microfilter and air recirculation ensures pleasant conditions in the interior.

■ The standard seats with Move cloth upholstery in Anthracite provide multiple adjustment options for an ideal seat position.

Selected base model equipment features:

- 16" light alloy wheels V-spoke style 378
- LED headlights
- Leather steering wheel
- 1-zone automatic air conditioning
- Radio BMW Professional



□ 17" light alloy wheels Y-spoke style 380, 7J x 17 with 205/50 R17 tyres.

LUXURY LINE.

Equipment 24 | 25

■ Standard equipment □ Optional equipment



■ The sport leather steering wheel with Pearl-Gloss Chrome detailing and 'Fineline' Stream fine-wood trim with Oxide Silver matt accent line add elegant visual highlights.

□ The sport seats, shown here with Dakota leather upholstery in Cognac, feature raised side bolsters for outstanding support.

■ 17" light alloy wheels Double-spoke style 724 Ferric Grey gloss-lathed, 7.5J x 17 with 225/45 R17 tyres.

Luxury Line exterior equipment:

- BMW kidney grille with eleven exclusively designed vertical slats in Chrome high-gloss
- Front bumper with specific design elements in Chrome high-gloss
- 17" light alloy wheels Double-spoke style 724 or
- 18" light alloy wheels Double-spoke style 384 with mixed tyres; other wheels available
- Chrome Line Exterior
- Rear bumper with specific design elements in Chrome high-gloss
- Tailpipe trim strip in Chrome high-gloss

Luxury Line interior equipment:

- Door sill finishers in aluminium with "BMW" designation
- Seats in leather 'Dakota' Oyster with Oyster dark highlights; other upholsteries available
- Sport leather steering wheel
- Vehicle key with Pearl Chrome detailing
- Armrest front, sliding
- Decorative stitching on the upper portion of the instrument panel
- Interior trim finishers fine-wood trim 'Fineline' Stream with highlight trim finishers Pearl Chrome; other trims available
- Orange or White variable Ambient light

SPORT LINE.

Discover even more with the new BMW Brochures app. Available now, for your smartphone and tablet.

■ Standard equipment □ Optional equipment



■ The Sport Line's dynamic interior ambience is underscored by the high-gloss Black interior trim with matt Coral Red accent line.



□ The sport seats in Black 'Dakota' leather with Red highlights perfectly match the Sport Line design.

Sport Line exterior equipment:

- BMW kidney grille with eight exclusively designed vertical slats in Black high-gloss
- Front bumper with specific design elements in Black high-gloss
- 17" light alloy wheels Double-spoke style 725 or
- 18" light alloy wheels Double-spoke style 384 with mixed tyres; other wheels available
- Mirror caps in Black high-gloss, alternatively in body colour
- Rear bumper with specific design elements in Black high-gloss
- Tailpipe trim strip in Black Chrome

Sport Line interior equipment:

- Door sill finishers in aluminium with "BMW" designation
- Sport seats in cloth 'Corner' Anthracite with Grey or Red highlights; other upholstery options available
- Sport leather steering wheel with red contrast stitching, alternatively available with black stitching
- Vehicle key with Red detailing
- Armrest front, sliding
- Instrument cluster with speedometer and revolution counter with chronoscaling
- Decorative stitching on the upper portion of the instrument panel
- Interior trim finishers black high-gloss with highlight trim finishers Coral Red matt; other trims available
- Driving Experience Control with additional SPORT+ mode
- Orange or White variable Ambient light



■ 17" light alloy wheels Double-spoke style 725 Bicolour Jet Black, wheel size 7.5J x 17 with 225/45 R17 tyres.



□ 18" light alloy wheels Double-spoke style 384 Bicolour Jet Black with mixed tyres, front 7.5J x 18 with 225/40 R18 tyres, rear 8J x 18 with 245/35 R18 tyres.



■ When the front doors are opened, one's eyes are immediately drawn to the BMW Sport door sill finishers made of aluminium.

M SPORT PACKAGE.

Discover even more with the new BMW Brochures app. Available now, for your smartphone and tablet.

powered by 

■ Standard equipment □ Optional equipment



■ In the interior of the new BMW 2 Series Coupé, the M leather steering wheel with M emblem and the Aluminium Hexagon interior trim with high-gloss Black accent line underscore the vehicle's sporting credentials.



□ The sport seats in Black 'Dakota' leather with Blue contrast stitching also feature discreet piping in the traditional M colours.

M Sport package exterior equipment:

- M Aerodynamics package with front apron, side skirts and rear apron with diffuser insert in Dark Shadow metallic
- BMW kidney grille with eight exclusively designed vertical slats with front sides in Black high-gloss
- 17" M light alloy wheels Double-spoke style 460 M with mixed tyres; other wheels available
- M Sport suspension, alternatively Adaptive M suspension
- BMW Individual high-gloss Shadow Line
- M logo on the sides
- Exclusive paintwork in Estoril Blue metallic; other paintworks available
- Tailpipe trim strip in Chrome high-gloss

M Sport package interior equipment:

- M door sill finishers, M driver footrest, knee pad on the right of the driver's footwell
- Sport seats for driver and front passenger in cloth/Alcantara combination 'Hexagon', Anthracite; other upholsteries available
- M Leather steering wheel
- Vehicle key with Estoril Blue detailing
- Armrest front, sliding
- BMW Individual headliner anthracite²
- Instrument cluster with speedometer and revolution counter with chronoscaling
- Decorative stitching on the upper portion of the instrument panel
- Air conditioning and radio control unit with Pearl Chrome detailing
- Interior trim finishers in Aluminium Hexagon with highlight trim finishers in Blue matt; other trims available
- Shortened gear lever with M designation¹ (for manual transmission)
- Driving Experience Control with additional SPORT+ mode
- Orange or White variable Ambient light



■ 17" M light alloy wheels Double-spoke style 460 M with mixed tyres, front 7.5J x 17 with 225/45 R17 tyres, rear 8J x 17 with 245/40 R17 tyres.



□ 18" M light alloy wheels Double-spoke style 719 M Bicolour Jet Black with mixed tyres, front 7.5J x 18 with 225/40 R18 tyres, rear 8J x 18 with 245/35 R18 tyres.



□ The M seat belts with belt tensioner and belt force limiter boast an exquisite woven highlight in the classic M colours.

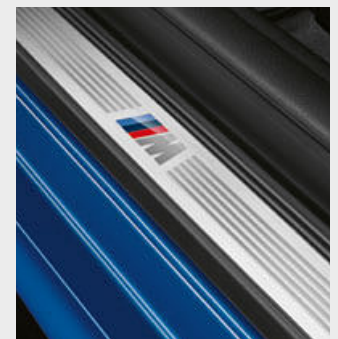

■ When the front doors are opened, one's eyes are automatically drawn towards the M door sill finishers made of aluminium.

¹ Not available in conjunction with Steptronic transmission.
² Only available for the BMW 2 Series Coupé.

THE BMW M240i.

Impressive driving dynamics and a genuine motorsport feel are hallmarks of the BMW M240i. With its unmistakably athletic sound, the vehicle's M TwinPower Turbo inline 6-cylinder petrol engine is engineered to delight. With a breathtaking output of 250 kW (340 hp), it is just the thing for anybody who ever dared to dream of more performance. Its optimised cooling system is well up to the task of dealing with its heightened performance. A low-set, optionally available Adaptive M suspension with variable damper control and even more athletic suspension and damping rates, spontaneous variable sport steering and M Sport brakes combine to masterfully transmit power to the road. While the M Aerodynamics package offers an excellent visual interpretation of the vehicle's athletic pedigree. The package includes a front apron with larger air inlets, special side skirts and a rear apron with a diffuser insert. The striking tailpipes come in dark Chrome. The M240i rolls on 18" light alloy wheels in the exclusive M design. In the interior, driver and front-seat passenger enjoy Sport seats that offer outstanding lateral support. The easy-grip M Leather steering wheel with contrast stitching features multifunction buttons. Special interior trim finishers offer a tantalising visual foretaste of the vehicle's athletic potential.

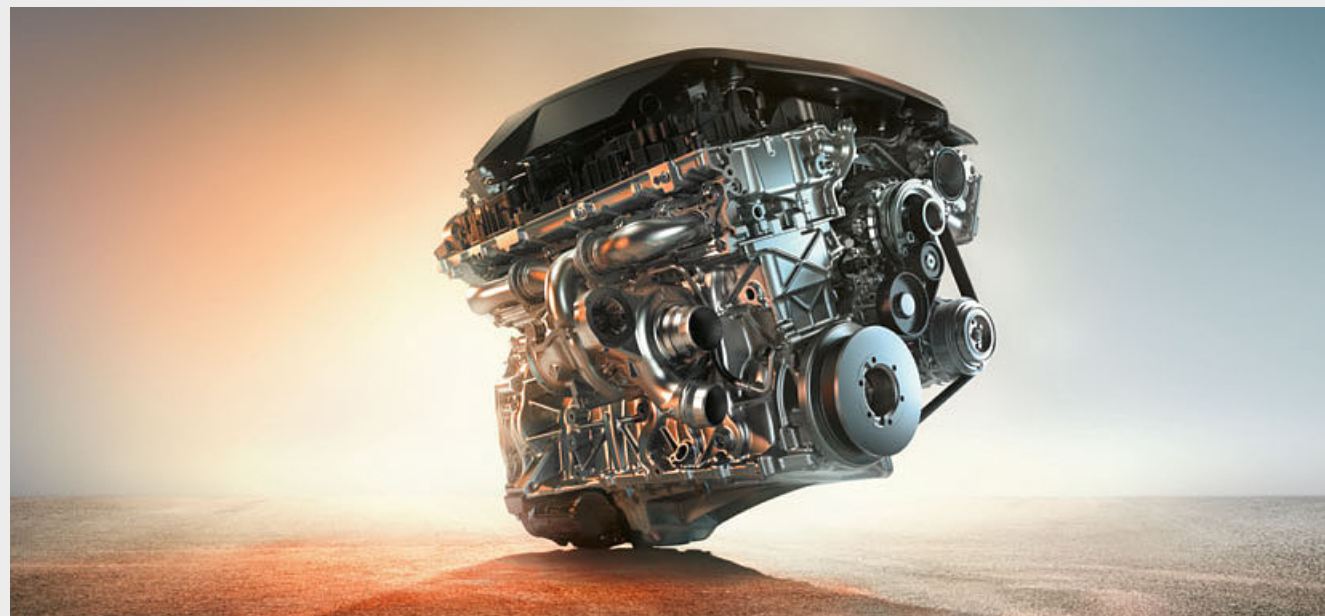

The M Aerodynamics package refines the entire aerodynamics even further. The M Aerodynamics package includes a front apron with larger air inlets, special side skirts and a rear apron with a diffuser insert. The tailpipes come in dark Chrome.



The instrument cluster with chronoscales and Info Display provides a clear overview of all relevant information while at the same time making you look forward to the drive, with M240i lettering that lights up when you start.

ADDITIONAL EQUIPMENT.

Discover even more with the new BMW Brochures app. Available now, for your smartphone and tablet.

■ Standard equipment □ Optional equipment



□ The Adaptive LED headlights include low-beam and high-beam headlights and turn indicators with full LED technology. The equipment also features BMW Selective Beam, cornering lights, daytime running lights and Adaptive headlights with variable light control for excellent illumination of the road ahead and better visibility in the dark.



□ The Wind deflector³ provides the driver and front passenger with effective protection from draughts at neck and shoulder-height, even when travelling at high speeds. When it is not needed, the collapsible sides can simply be folded together for easy and compact storage.



■ From the daytime running lights to the low-beams and high-beams, all of the functions in the LED headlights have a longer lifespan and save more energy thanks to LED technology. The dynamic, flat headlights feature automatic light range regulation and increased visibility at night and in bad weather thanks to excellent illumination with a light colour similar to daylight.



□ The light generated by the LED fog lights is very similar to daylight and enables the driver to see better and drive more safely in inclement weather.



□ The mirror caps are painted high-gloss Black^{1,5} instead of in the body colour. They emphasise the car's athletic look and create an individual appearance.



□ The Comfort access system allows passengers to enter the car via the front doors and open the tailgate without having to actively use the key. The key must simply be nearby, in the driver's trouser pocket for example. To unlock the doors, it is only necessary to touch the handles or the tailgate button.



□ The Storage compartment package offers a multitude of additional storage options, including fastening points in the luggage compartment.



□ The Trailer tow hitch with removable ball head and trailer stability control is capable of pulling loads of up to 1.500 kg.⁴



□ The Chrome Line Exterior features front and rear side window recess finishers, the trim on the A-pillars as well as the softtop cover trim strips in high-gloss Chrome. This emphasises the exterior's highly sophisticated appearance.



□ The electrical Glass roof² with slide and lift function including sun protection, anti-trap protection, comfort opening and closing via remote control and one-touch function allows you to regulate the air flow rate according to your preference to create a pleasant interior climate. The integrated, automatically extending wind deflector guarantees a high level of acoustic comfort.



■ The Convertible softtop³ considerably reduces the noise level in the interior and also provides outstanding insulation against the cold. No matter whether seen from the inside or outside, its high-quality look is a real headturner. The softtop can even be opened or closed fully automatically at speeds of up to 50 km/h.

¹ Only in conjunction with Sport Line.

² Only available for the BMW 2 Series Coupé.

³ Only available for the BMW 2 Series Convertible.

⁴ The actual total weight of the trailer must not exceed the maximum trailer load, taking into account the maximum tow bar download.

⁵ Standard for BMW M240i and BMW M240i xDrive.

The Standard and Optional equipment may differ between countries. Please consult your local BMW partner for more information.

ADDITIONAL EQUIPMENT.

Discover even more with the new BMW Brochures app. Available now, for your smartphone and tablet.

■ Standard equipment □ Optional equipment

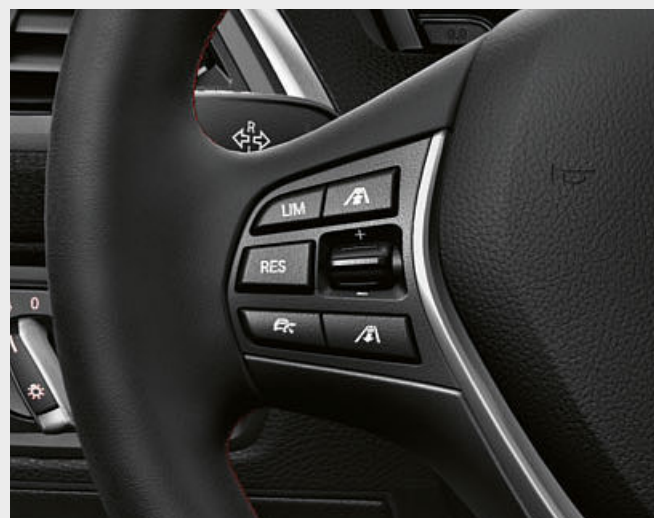

□ Active cruise control with Stop&Go function* maintains a preselected speed, as well as the distance to the driver ahead.



□ The Sport seats for driver and front passenger provide optimum lateral support with their raised side bolsters and manually adjustable thigh support. The fore-and-aft position and seat angle can be manually adjusted, while the backrest width can be adjusted electrically.



□ Telephony with wireless charging^{1,4} includes a wireless charging dock and additional USB ports. A roof aerial connection improves mobile reception. Two mobile telephones and an audio player can be connected simultaneously via Bluetooth. Also included are: Bluetooth Office and the technical capacity for a WiFi hotspot.



□ When the rear-seat backrest is folded down, a large practical through-loading gap, which is 450 mm wide and 246 mm high, becomes available for the easy transportation of longer objects, such as sport equipment.² The back of the rear-seat backrest serves as a storage surface. A remote unlocking button in the rear offers a high level of operating comfort.



□ The Navigation system Professional*, including USB interface, 8.8" LCD colour display and Radio BMW Professional with a DVD player, comes with a three-dimensional map display and 20 GB of memory. The system is operated intuitively via the iDrive Touch Controller or touch screen. Map updates are available for three years without license fees.



□ The Instrument cluster with extended contents* includes Info Display for the presentation of navigation instructions and various controls.



□ The Multifunction buttons for the steering wheel can be used to operate the telephone, voice control and audio functions, as well as the Manual Speed Limiter.



□ The 8-speed Steptronic Sport transmission* offers incredibly sporty gear changes. Whether automatic or manual using gearshift paddles or gear lever.



□ The HiFi loudspeaker system Harman Kardon with external 360 watt amplifier in the luggage compartment consists of 12 speakers including two central subwoofers.



□ The Automatic air conditioning with two-zone control and automatic temperature regulation features separate controls for the driver and front passenger. It includes rear air vents, Automatic Air Recirculation (AAR), an active carbon filter, fogging and solar sensors, as well as automatic day/night adjustment in the display from white to orange.



□ The Parking Assistant⁵* makes parking parallel and perpendicular to the road easier. The system works by measuring even tight potential parallel parking spaces while driving past at a low speed. When a suitable space has been found, the Parking Assistant takes over the steering, while the driver is responsible for selecting the correct gear, as well as pressing the accelerator and brakes.



□ The Rear view camera* enables improved orientation when reversing at speeds below 15 km/h, for example when parking. It shows the area behind the car on the Control Display. Interactive track lines for measuring distance and turning circles assist the driver when manoeuvring, obstacles are marked in colour.

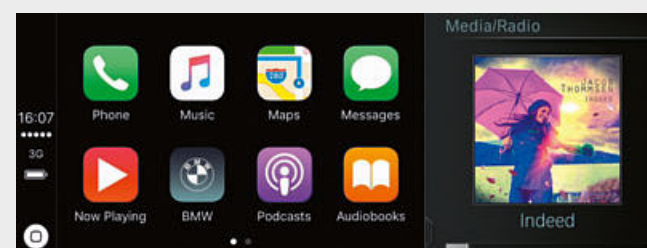

□ Why go without the features of your iPhone in your BMW when you can continue operating it as usual? The preparation for Apple CarPlay^{3,*} gives you remote access to telephony as well as apps like iMessage, WhatsApp, TuneIn, Spotify and Apple Music. You can also use the voice button on the steering wheel to access Siri, Apple's voice assistant.

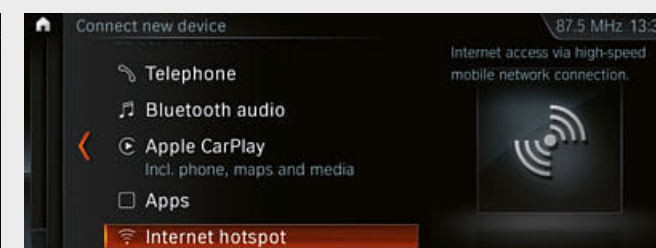

□ Take part in video conference calls on your tablet or stream the final episode of your favourite series on your smartphone. The Wi-Fi Hotspot⁴ is a way to go online with LTE speed (if available) using the SIM card installed in your vehicle. You and your fellow passengers can surf the Web on up to ten devices.

¹ Supports inductive charging for Qi-compatible mobile phones. Special charging cases are available from Original BMW Accessories for selected smartphones that do not support the Qi standard for inductive charging. The WiFi hotspot fulfils all in-vehicle requirements for use of the internet with the maximum LTE standard. Usage is subject to cost.

² Through-loading hatch only available for the Convertible. Coupé with 40:20:40-split rear seatback.

³ Apple CarPlay[®] compatibility and supported functions depend on the model year and the software installed on the iPhone[®]. When the Apple CarPlay[®] preparation is used, selected vehicle data is transferred to the phone. The mobile phone manufacturer is responsible for further data processing.

⁴ The WiFi hotspot fulfils all in-vehicle requirements for use of the internet with the maximum LTE standard. Usage is subject to cost.

⁵ The driver is responsible for constantly monitoring the automated parking procedure in accordance with local road laws.

* The availability of some equipment features and functions depends on engine variants or additional options. The market and production availability may vary. You can find detailed information about terms, standard and optional equipment at www.bmw.com or from your BMW Partner.

The Standard and Optional equipment may differ between countries. Please consult your local BMW partner for more information. Some ConnectedDrive Services may differ between countries. Please consult your local BMW partner for more information.

EXTERIOR COLOURS.

Discover even more with the new BMW Brochures app. Available now, for your smartphone and tablet.

■ Standard equipment □ Optional equipment

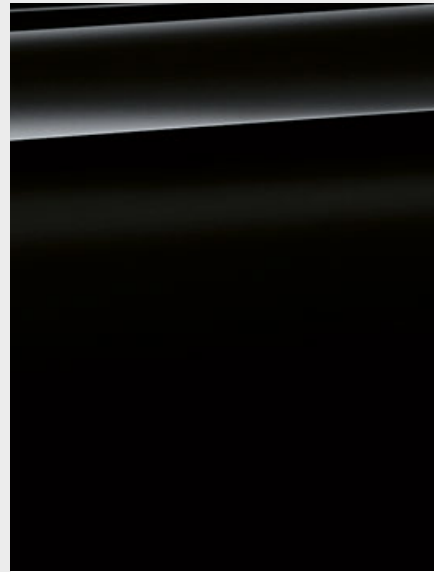

■ Non-metallic 668 Black¹

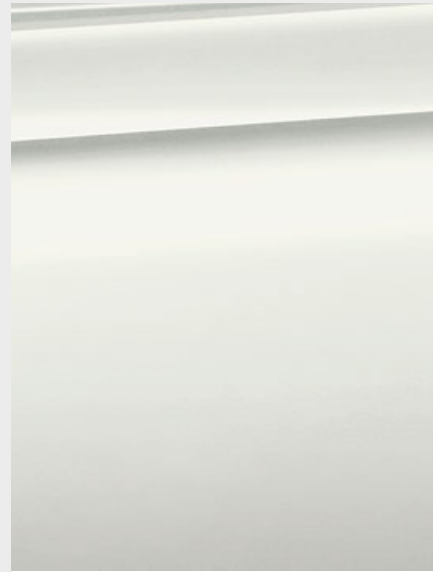

□ Non-metallic 300 Alpine White³

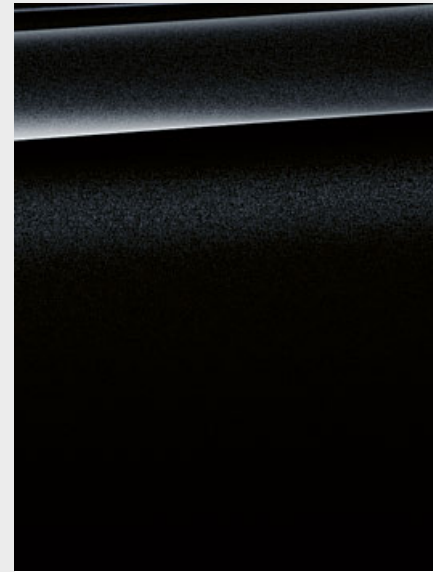

□ Metallic 475 Sapphire Black⁴



□ Metallic A96 Mineral White⁴



□ Metallic A83 Glacier Silver¹

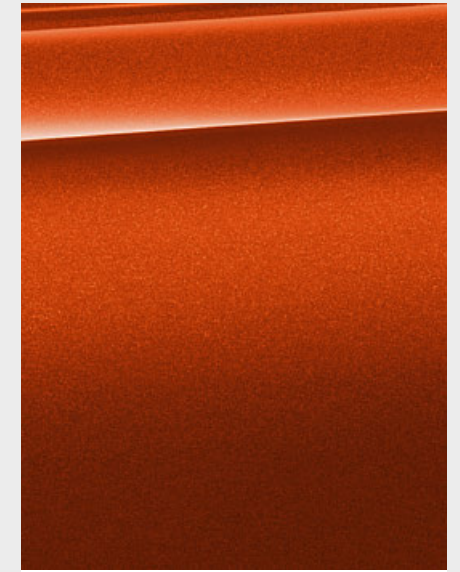

□ Metallic C1X Sunset Orange⁴

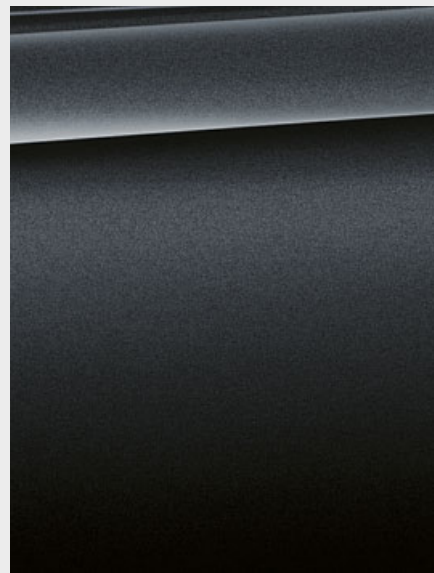

□ Metallic B39 Mineral Grey⁴



□ Metallic C16 Long Beach Blue⁵

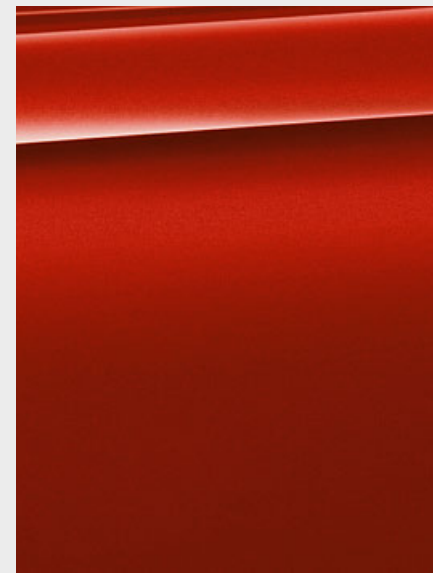

□ Metallic A75 Melbourne Red^{1,4}

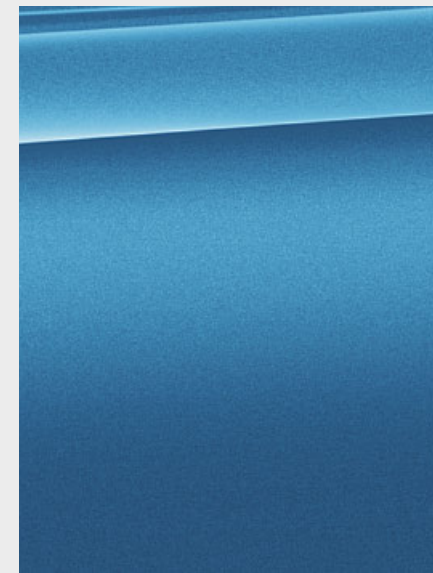

□ Metallic C1R Seaside Blue¹



□ Metallic B45 Estoril Blue²

M SPORT PACKAGE

[Colours] The colours printed above are intended to provide you with a first impression of paints and materials available for your BMW. Experience has shown, however, that printed images of paint, upholstery and interior trim colours cannot faithfully reproduce the actual

appearance of the originals. We recommend therefore that you consult your BMW partner who will be able to show you original samples and assist with special requests.

¹ Not available for BMW M240i and M240i xDrive.

² Only available in conjunction with the M Sport package.

³ Available as standard for the M Sport package.

⁴ Optionally available for the M Sport package.

⁵ Only available for BMW M240i and BMW M240i xDrive.

The Standard and Optional equipment may differ between countries. Please consult your local BMW partner for more information.

INTERIOR COLOURS.

Discover even more with the new BMW Brochures app. Available now, for your smartphone and tablet.

■ Standard equipment □ Optional equipment

CLOTH

Available with

- Base

Cloth 'Move' BDAT Anthracite*

- Base
- Sport Line
- M Sport package

Cloth 'Corner' CCL1 Anthracite with Grey highlights

- Sport Line

Cloth 'Corner' CCL2 Anthracite with Red highlights

LEATHER

Available with

- Base
- Luxury Line
- Sport Line
- M Sport package

Leather 'Dakota' LCLZ Black with exclusive stitching, interior colour Black

- Base
- Luxury Line
- Sport Line
- M Sport package

Leather 'Dakota' LCOM Oyster, Oyster dark highlight, interior colour in Black

- Base
- Luxury Line
- Sport Line
- M Sport package

Leather 'Dakota' LCL9 Oyster, Oyster dark highlight, interior colour in Oyster

- Sport Line
- M Sport package

Leather 'Dakota' LCL5 Coral Red with Black highlight

- Sport Line

Leather 'Dakota' LCL3 Black with Red highlight

CLOTH/LEATHER COMBINATION

Available with

- M Sport package

Cloth/Alcantara combination 'Hexagon' HAAT Anthracite

- Base
- Sport Line

Cloth/leather combination 'Breeze' CBAT Anthracite, interior colour in Black

- Base
- Luxury Line
- Sport Line
- M Sport package

Leather 'Dakota' LCRY Cognac with Brown highlight

- M Sport package

Leather 'Dakota' LCNL Black with Blue contrast stitching

INTERIOR TRIM FINISHERS

Available with

- Base

4CG Satin Silver matt

- Base
- Sport Line
- M Sport package

4LU Black high-gloss, highlight trim finisher Pearl Chrome

- Sport Line

4LV High-gloss Black with matt Coral Red accent line

- Base
- Luxury Line
- Sport Line
- M Sport package

4FT Fine Brushed Aluminium with high-gloss Black accent line

- Base
- Luxury Line
- Sport Line
- M Sport package

4LS Aluminium, finely brushed lengthwise, highlight trim finishers Pearl Chrome

- M Sport package

4WG Aluminium Hexagon with high-gloss Black accent line

- M Sport package

4WF Aluminium Hexagon with matt Blue accent line

- M Sport package

4MC Carbon Fibre, open-pored with high-gloss Black highlight trim finisher^{1,2,*}

INTERIOR TRIM FINISHERS

Available with

- Base
- Luxury Line
- Sport Line
- M Sport package

4LR Fine-wood trim Fineline Stream, highlight trim finishers Pearl Chrome

INTERIOR FINISHES

Available with

- Base
- Luxury Line
- Sport Line
- M Sport package

Black

- Base
- Luxury Line
- Sport Line
- M Sport package

Oyster

SOFTTOP COLOURS

Available with

- Base
- Luxury Line
- Sport Line
- M Sport package

388 Black³

- Base
- Luxury Line
- Sport Line
- M Sport package

3YA Anthracite silver effect³

- Base
- Luxury Line
- Sport Line
- M Sport package

3YF Brown silver effect³

Please note that even normal long- or short-term use can lead to unrecoverable upholstery damage. This can be caused in particular by non-colourfast clothing. Please note that the interior colour depends on the selected upholstery colour.

¹ Available as optional equipment.
² Only available for BMW M240i and BMW M240i xDrive.
³ Only available for the BMW 2 Series Convertible.

*The availability of some equipment features and functions depends on engine variants or additional options. The market and production availability may vary. You can find detailed information about terms, standard and optional equipment at www.bmw.com or from your BMW Partner.

WHEELS AND TYRES.

Discover even more with the new BMW Brochures app. Available now, for your smartphone and tablet.



□ 16" light alloy wheels Star-spoke style 376, 7J x 16 with 205/55 R16 tyres



■ 16" light alloy wheels V-spoke style 378, 7J x 16 with 205/55 R16 tyres.



□ 17" light alloy wheels Star-spoke style 379, Orbit Grey, gloss-lathed, 7.5J x 17 with 225/45 R17 tyres.



□ 17" light alloy wheels Double-spoke style 655, 7.5J x 17, 225/45 R17 tyres.



■ 17" light alloy wheels Double-spoke style 725 Bicolour³ Jet Black, wheel size 7.5J x 17 with 225/45 R17 tyres.



□ 17" light alloy wheels Y-spoke style 380, 7J x 17 with 205/50 R17 tyres.



□ 18" light alloy wheels Double-spoke style 384 Bicolour Jet Black with mixed tyres, front 7.5J x 18 with 225/40 R18 tyres, rear 8J x 18 with 245/35 R18 tyres.



■ 18" M light alloy wheels Double-spoke style 719 M Cerium Grey matt² with mixed tyres, front 7.5J x 18 with 225/40 R18 tyres, rear 8J x 18 with 245/35 R18 tyres.



□ 18" M light alloy wheels Double-spoke style 719 M Jet Black¹ with mixed tyres, front 7.5J x 18 with 225/40 R18 tyres, rear 8J x 18 with 245/35 R18 tyres.

ORIGINAL BMW ACCESSORIES.

■ Standard equipment □ Optional equipment ○ Accessories



○ The modern BMW roof box in black with titanium silver side panels has a storage capacity of 420 litres and is compatible with all BMW roof rack systems. Due to the fact that it can be opened from both sides and has triple central locking on each side it is convenient to load and lock for theft protection.



○ 19" light alloy wheels Star-spoke style 660 in Bicolour Orbit Grey, gloss-lathed on the visible side. TPMS complete summer wheel set with mixed-size run-flat tyres, wheel size 7.5J x 19 with tyre size 225/35 R19 88Y XL at the front and 8J x 19 with tyre size 245/30 R19 89Y XL at the rear.



○ The clothes hanger can be clipped into the basic carrier (available separately) via a plug-in coupling system and can also be used outside the car.



○ Precisely fitting protection against moisture and dirt in the front footwell. Coloured black with a red edge, the mats perfectly match the interior.

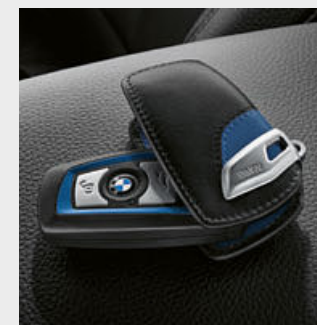

○ The key pouch, made from quality leather, protects from soiling and inadvertent pressing of buttons. In black and blue, to complement the M Sport package.

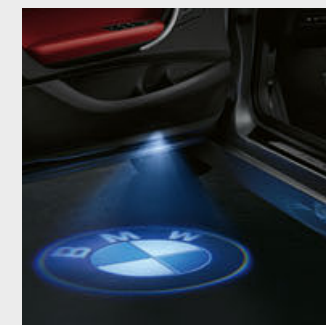

○ When the doors are opened, one of a choice of four graphics is projected on the ground adjacent to the vehicle, for perfect illumination of the entry area.



○ Anti-slip, water-resistant, durable mat for protecting the luggage compartment from dirt and moisture. In black/red; colouring complements the interior.

¹ Only available in conjunction with the M Sport package.
² Only available for BMW M240i and BMW M240i xDrive.
³ Only in conjunction with Sport Line.

The Standard and Optional equipment may differ between countries. Please consult your local BMW partner for more information.

Discover the wide range of innovative solutions available for the exterior and interior, communication and information, and for transportation and the luggage compartment.

Your BMW Partner is on hand to advise you on the whole range of Original BMW Accessories. For further information, please visit www.bmw.com

BMW 2 SERIES COUPÉ

TECHNICAL DATA.	BMW 2 SERIES COUPÉ					
	218i	220i	230i	M240i M240i xDrive	218d	220d 220d xDrive

Weight							
Unladen weight EU¹ (xDrive)	kg	1420 [1440]	[1480]	[1505]	[1565-1585] ([1615-1635])	1495 [1515]	1505 [1530] ([1605])
Max. permissible weight (xDrive)	kg	1850 [1870]	[1910]	[1935]	[1995] ([2050])	1930 [1950]	1945 [1965] ([2040])
Permitted load (xDrive)	kg	505 [505]	[505]	[505]	[485-505] ([490-510])	510 [510]	515 [510] ([510])
Permitted trailer load, unbraked² (xDrive)	kg	680 [680]	[680]	[715]	-	715 [715]	725 [725] ([750])
Permitted trailer load, braked, max. 12% gradient/max. 8% gradient² (xDrive)	kg	1300/1500 [1300/1500]	[1500/1500]	[1500/1500]	-	1500/1500 [1500/1500]	1500/1500 [1500/1500] ([1500/1500])
Luggage capacity	l	390	390	390	390	390	390

Engine⁴							
Cylinders/valves		3/4	4/4	4/4	6/4	4/4	4/4
Capacity	cm³	1499	1998	1998	2998	1995	1995
Max. output/engine speed	kW (hp)/rpm	100 (136)/ 4400-6000	135 (184)/ 5000-6500	185 (252)/ 5200-6500	250 (340)/ 5500-6500	100-110 (136-150)/ 4000	140 (190)/ 4000
Max. torque/engine speed	Nm/rpm	220/1350-4300	270/1350-4600	350/1450-4800	500/1550-4500	320/1500-3000 1500-2750	400/1750-2500

Power transmission							
Type of drive		Rear-wheel	Rear-wheel	Rear-wheel	Rear-wheel/all-wheel	Rear-wheel	Rear-wheel/all-wheel
Standard transmission (xDrive)		6-speed manual	8-speed Steptronic	8-speed Steptronic	8-speed Steptronic	6-speed manual	6-speed manual (8-speed Steptronic)

Driving performance							
Top speed (xDrive)	km/h	210 [210]	[230]	[250]⁵	[250]⁵ ([250])⁵	211-213 [211-213]	230 [230] ([225])
Acceleration (xDrive) 0-100 km/h	s	8.8 [8.9]	[7.2]	[5.6]	[4.6] ([4.4])	8.5-9.2 [8.3-8.9]	7.2 [7.1] ([7.0])

Consumption³, ⁴ - All engines conform to the EU6 standard							
Urban (xDrive)	l/100 km	7.4 [7.0-7.2]	[7.3]	[7.2-7.3]	[9.3-9.4] ([9.9-10.1])	5.4 [5.1-5.3]	5.5-5.6 [5.2-5.3] (5.8-6.0)
Extra-urban (xDrive)	l/100 km	5.2-5.4 [5.0-5.1]	[4.9-5.1]	[4.9-5.2]	[6.2] ([6.6-6.7])	4.2-4.3 [4.0-4.2]	4.3-4.4 [4.1-4.2] (4.6-4.7)
Combined (xDrive)	l/100 km	6.0-6.2 [5.7-5.9]	[5.8-5.9]	[5.8-6.0]	[7.3-7.4] ([7.8-8.0])	4.7 [4.4-4.5]	4.7-4.8 [4.5-4.6] (5.0-5.1)
Exhaust emissions standard (type-certified)		EU6d-temp [EU6d-temp]	[EU6d-temp]	[EU6d-temp]	[EU6d-temp]	EU6d-temp [EU6d-temp]	EU6d-temp [EU6d-temp]
Combined CO₂ emissions (xDrive)	g/km	137-140 [130-133]	[132-135]	[132-138]	[167-168] ([178-181])	122-124 [116-119]	124-127 [120-121] ([132-135])
Tank capacity, approx.	l	52	52	52	52	52	52

Wheels/tyres							
Tyre dimensions		205/55 R16 V	205/55 R16 V	205/50 R17 Y	225/40 ZR18 Y / 245/35 ZR18 Y	205/55 R16 V	205/55 R16 V
Wheel size		7J x 16	7J x 16	7J x 17	7.5J x 18 / 8J x 18	7J x 16	7J x 16
Material		light alloy	light alloy	light alloy	light alloy	light alloy	light alloy

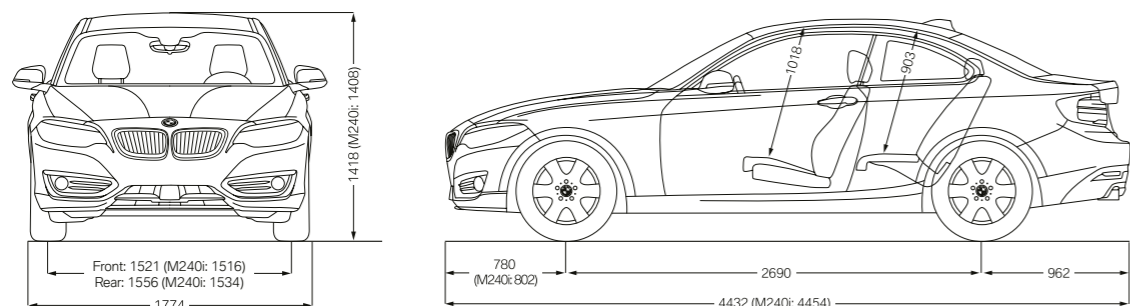

All dimensions in the technical drawing are given in millimetres.
The figures for performance, fuel consumption and CO₂ emissions refer to vehicles with standard transmission. Figures in [] are for vehicles with Steptronic transmission.

¹ The EC unladen weight refers to a vehicle with standard equipment and does not include any optional extras. The unladen weight includes a 90% full tank and a driver weight of 75 kg. Optional equipment may affect the weight of the vehicle, the payload and the top speed if the selected equipment has an impact on the vehicle's aerodynamics.

² The actual total weight of the trailer must not exceed the maximum trailer load, taking into account the maximum tow bar download.

³ The data for fuel consumption, CO₂ emissions and energy consumption are determined in accordance with the measurement processes as defined by European Regulation (EC) 715/2007 in the applicable version. Data refer to a vehicle with base-level equipment in Germany, and the ranges account for differences according to the selected wheel and tyre size and the optional equipment and may change during the configuration process. Figures have been determined on the basis of the new WLTP test cycle and have been converted back into NEDC figures for comparability. [For these vehicles, values other than those specified here may apply for the assessment of taxes and other vehicle-related charges that are (also) based on CO₂ emissions.]

BMW 2 SERIES CONVERTIBLE

TECHNICAL DATA.	BMW 2 SERIES CONVERTIBLE					
	218i	220i	230i	M240i M240i xDrive	218d	220d

Weight							
Unladen weight EU¹ (xDrive)	kg	1575 [1595]	[1615]	[1650]	[1710] ([1760])	1640 [1660]	1660 [1675]
Max. permissible weight (xDrive)	kg	1965 [1985]	[2010]	[2020]	[2060] ([2110])	2015 [2035]	2035 [2055]
Permitted load (xDrive)	kg	465 [465]	[470]	[445]	[425] ([425])	450 [450]	450 [455]
Permitted trailer load, unbraked² (xDrive)	kg	750 [750]	[750]	[750]	-	750 [750]	750 [750]
Permitted trailer load, braked, max. 12% gradient/max. 8% gradient² (xDrive)	kg	1300/1500 [1300/1500]	[1500/1500]	[1500/1500]	-	1500/1500 [1500/1500]	1500/1500 [1500/1500]
Luggage capacity	l	280-335	280-335	280-335	280-335	280-335	280-335

Engine⁴							
Cylinders/valves		3/4	4/4	4/4	6/4	4/4	4/4
Capacity	cm³	1499	1998	1998	2998	1995	1995
Max. output/engine speed	kW (hp)/ rpm	100 (136)/ 4400-6000	135 (184)/ 5000-6500	185 (252)/ 5200-6500	250 (340)/ 5500-6500	110 (150)/ 4000	140 (190)/ 4000
Max. torque/engine speed	Nm/rpm	220/ 1350-4300	270/ 1350-4600	350/ 1450-4800	500/ 1550-4500	320/ 1500-3000	400/ 1750-2500

Power transmission							
Type of drive		Rear-wheel	Rear-wheel	Rear-wheel	Rear-wheel/all-wheel	Rear-wheel	Rear-wheel
Standard transmission (xDrive)		6-speed manual 8-speed Steptronic	8-speed Steptronic	8-speed Steptronic	8-speed Steptronic	6-speed manual 8-speed Steptronic	6-speed manual 8-speed Steptronic

Driving performance							
Top speed (xDrive)	km/h	207 [205]	[226]	[250]⁵	[250]⁵ ([250])⁵	208 [205]	225 [225]
Acceleration (xDrive) 0-100 km/h	s	9.4 [9.6]	[7.7]	[5.9]	[4.7] ([4.6])	9.0 [8.8]	7.6 [7.5]

Consumption³, ⁴ - All engines conform to the EU6 standard							
Urban (xDrive)	l/100 km	7.8-8.1 [7.4-7.6]	[7.1-7.2]	[7.4-7.5]	[9.8-9.9] ([10.6-10.9])	5.7-5.8 [5.4-5.5]	5.8-5.9 [5.4]
Extra-urban (xDrive)	l/100 km	5.5-5.6 [5.4-5.5]	[5.5-5.7]	[5.4-5.6]	[6.3] ([6.9-7.0])	4.6-4.7 [4.4-4.5]	4.6-4.8 [4.3-4.4]
Combined (xDrive)	l/100 km	6.3-6.5 [6.1-6.3]	[6.1-6.2]	[6.2-6.3]	[7.6] ([8.3-8.4])	5.0-5.1 [4.7-4.8]	5.1-5.2 [4.7-4.8]
Exhaust emissions standard (type-certified)		EU6d-temp [EU6d-temp]	[EU6d-temp]	[EU6d-temp]	[EU6d-temp]	EU6d-temp [EU6d-temp]	EU6d-temp [EU6d-temp]
Combined CO₂ emissions (xDrive)	g/km	144-148 [139-143]	[139-142]	[141-144]	[172-173] ([188-191])	131-134 [123-127]	133-136 [124-126]
Tank capacity, approx.	l	52	52	52	52	52	52

Wheels/tyres							
Tyre dimensions		205/55 R16 H	205/55 R16 W	205/50 R17 Y	225/40 ZR18 Y / 245/35 ZR18 Y	205/55 R16 V	205/55 R16 W
Wheel size		7J x 16	7J x 16	7J x 17	7.5J x 18 / 8J x 18	7J x 16	7J x 16
Material		light alloy	light alloy	light alloy	light alloy	light alloy	light alloy

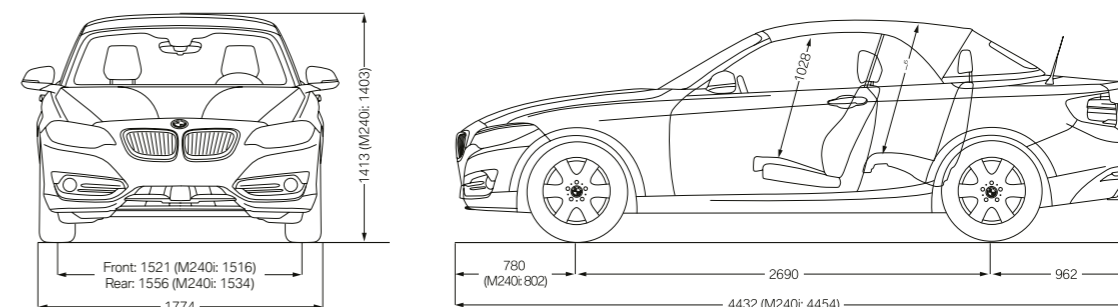

⁴ Performance data of petrol engines apply to vehicles using RON 98 fuel. Fuel consumption data apply to vehicles using reference fuels in accordance with EU Regulation 2007/715. Unleaded RON 91 and higher with a maximum ethanol content of 10% (E10) may also be used. BMW recommends RON 95 super unleaded petrol.
⁵ Electronically limited.

BMW M240i COUPÉ:

M Performance TwinPower Turbo 6-cylinder in-line petrol engine, 250 kW (340 hp), 18" M light alloy wheels Double-spoke style 719 M Jet Black, exterior colour in Sunset Orange metallic, seats in Black Dakota leather, Aluminium Hexagon interior trim with high-gloss Black accent line.

BMW 230i CONVERTIBLE WITH LUXURY LINE:

BMW TwinPower Turbo 4-cylinder petrol engine, 185 kW (252 hp), 17" light alloy wheels Double-spoke style 724 Ferric Grey, gloss-lathed, exterior colour in Seaside Blue metallic, soft top in Brown silver effect, seats in Cognac Dakota leather with Brown highlights, Finition Stream fine-wood trim with Pearl-Gloss Chrome accent line.

The models illustrated in this brochure show the equipment and configuration options (standard and optional) for vehicles produced by BMW AG for the German market. Alterations in standard and optional equipment and the configurations available for the different models, as described in this brochure, may occur after 03/18/2019, the date when this brochure went to press, or according to the specific requirements of other markets. Your local BMW Partner is available to provide further details. Subject to change in design and equipment.

© BMW AG, Munich, Germany. Not to be reproduced wholly or in part without prior written permission of BMW AG, Munich.

4 11 002 227 20 2 2019 CB. Printed in Germany 2019.

